

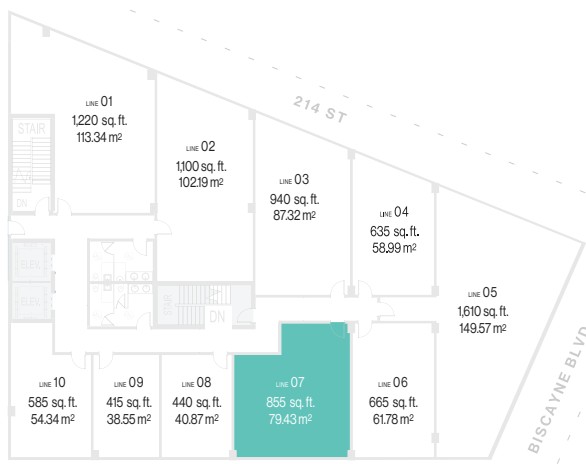

12|12
AVENTURA

FLOORPLAN

LINE 07
855 sq. ft.
79.43 m²



Ⓔ ALL INFORMATION IN THIS BROCHURE, AS WELL AS ANY ATTACHMENTS AND/OR REFERENCES HEREIN, SHALL NOT CONSTITUTE AN OFFER TO SELL OR A SOLICITATION OF AN OFFER TO BUY ANY INTEREST IN ANY SECURITY OR ANY SECURITY DERIVATIVE PRODUCTS OF ANY KIND, OR ANY TYPE OF TRADING OR INVESTMENT ADVICE, RECOMMENDATION OR STRATEGY. NO OFFER TO SELL OR SOLICITATION OF AN OFFER TO BUY AN INTEREST IN ANY SECURITY OR OTHER SUCH PRODUCT MAY BE MADE TO A PROSPECTIVE SUBSCRIBER (I) UNTIL A COPY OF THE APPLICABLE SUBSCRIPTION MATERIALS HAVE BEEN PROVIDED TO AND REVIEWED BY SUCH PROSPECTIVE PURCHASER, WHICH MUST BE COMPLETED AND RETURNED IN ACCORDANCE WITH THE TERMS THEREOF, (II) UNLESS MADE EXCLUSIVELY OUTSIDE THE UNITED STATES TO A PROSPECTIVE SUBSCRIBER WHO IS A NON-U.S. CITIZEN OR NON-U.S. PERMANENT RESIDENT IN ACCORDANCE WITH REGULATION S OF THE SECURITIES ACT OF 1933, AS AMENDED; AND (III) IN ANY JURISDICTION IN WHICH SUCH OFFER OR SOLICITATION IS UNLAWFUL. ANY REPRESENTATIONS TO THE CONTRARY ARE UNLAWFUL. WE MAKE NO GUARANTEE OR REPRESENTATION WITH RESPECT TO THE PERFORMANCE OF ANY INVESTMENT, THE SPECIFIC RATE OF RETURN ON ANY INVESTMENT NOR THE RETURN OF CAPITAL.



FLOORPLAN

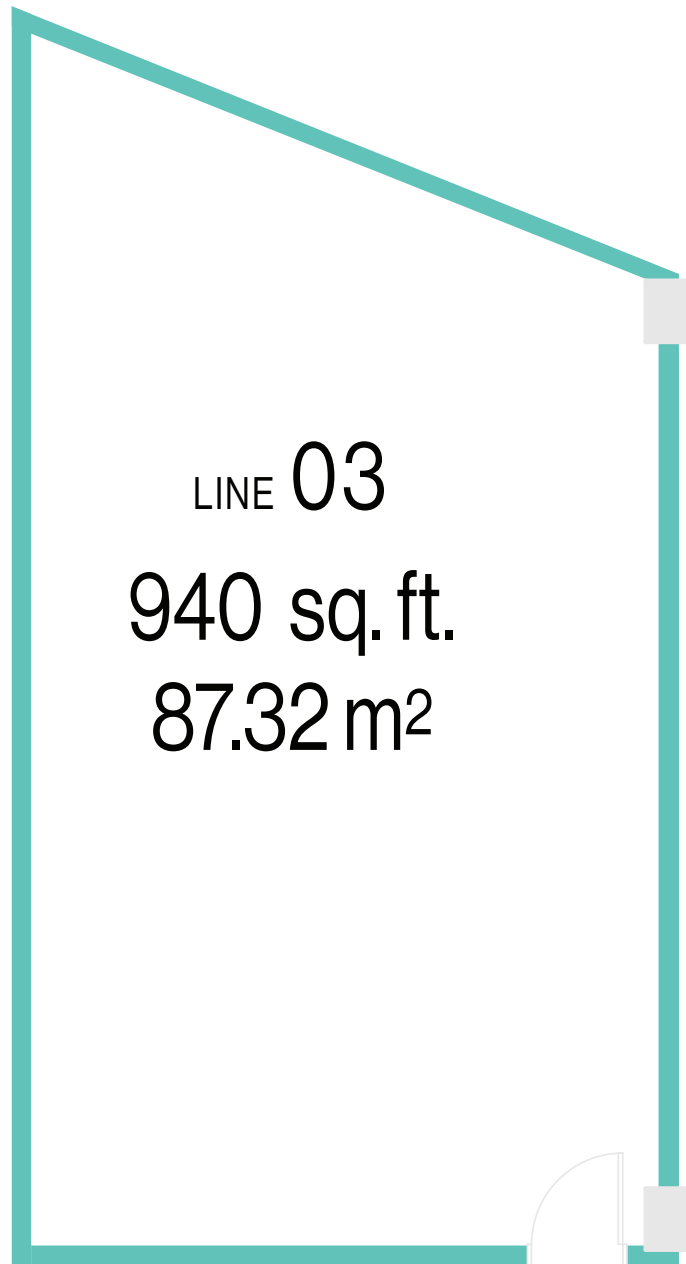

LINE 03
940 sq. ft.
87.32 m²

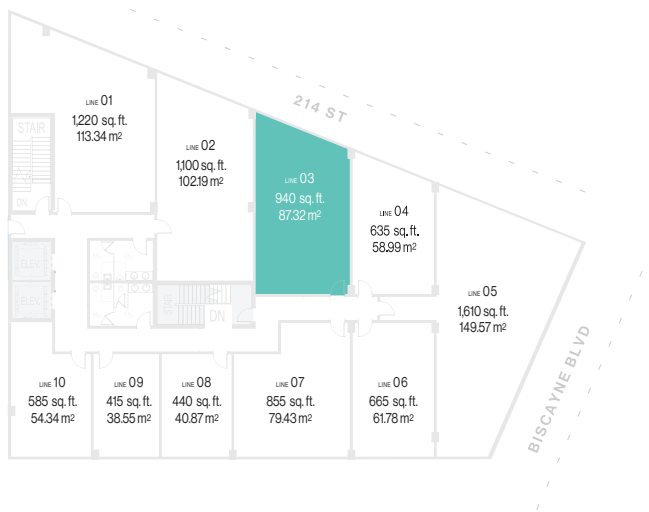

© ALL INFORMATION IN THIS BROCHURE, AS WELL AS ANY ATTACHMENTS AND/OR REFERENCES HEREIN, SHALL NOT CONSTITUTE AN OFFER TO SELL OR A SOLICITATION OF AN OFFER TO BUY ANY INTEREST IN ANY SECURITY OR ANY SECURITY DERIVATIVE PRODUCTS OF ANY KIND, OR ANY TYPE OF TRADING OR INVESTMENT ADVICE, RECOMMENDATION OR STRATEGY. NO OFFER TO SELL OR SOLICITATION OF AN OFFER TO BUY AN INTEREST IN ANY SECURITY OR OTHER SUCH PRODUCT MAY BE MADE TO A PROSPECTIVE SUBSCRIBER (I) UNTIL A COPY OF THE APPLICABLE SUBSCRIPTION MATERIALS HAVE BEEN PROVIDED TO AND REVIEWED BY SUCH PROSPECTIVE PURCHASER, WHICH MUST BE COMPLETED AND RETURNED IN ACCORDANCE WITH THE TERMS THEREOF, (II) UNLESS MADE EXCLUSIVELY OUTSIDE THE UNITED STATES TO A PROSPECTIVE SUBSCRIBER WHO IS A NON-U.S. CITIZEN OR NON-U.S. PERMANENT RESIDENT IN ACCORDANCE WITH REGULATION S OF THE SECURITIES ACT OF 1933, AS AMENDED; AND (III) IN ANY JURISDICTION IN WHICH SUCH OFFER OR SOLICITATION IS UNLAWFUL. ANY REPRESENTATIONS TO THE CONTRARY ARE UNLAWFUL. WE MAKE NO GUARANTEE OR REPRESENTATION WITH RESPECT TO THE PERFORMANCE OF ANY INVESTMENT, THE SPECIFIC RATE OF RETURN ON ANY INVESTMENT NOR THE RETURN OF CAPITAL.

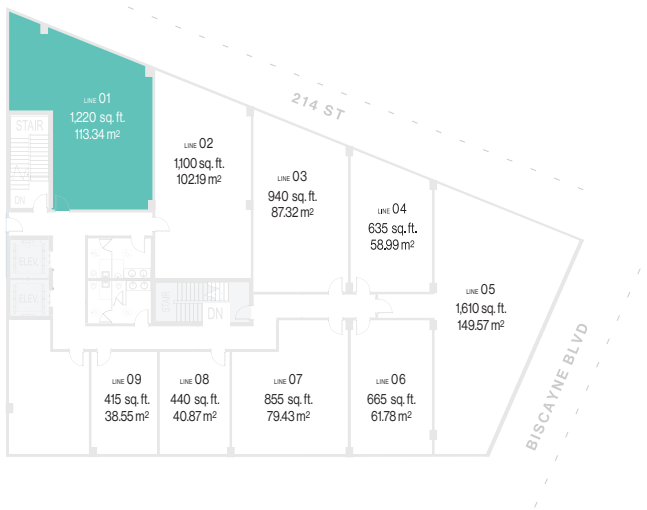
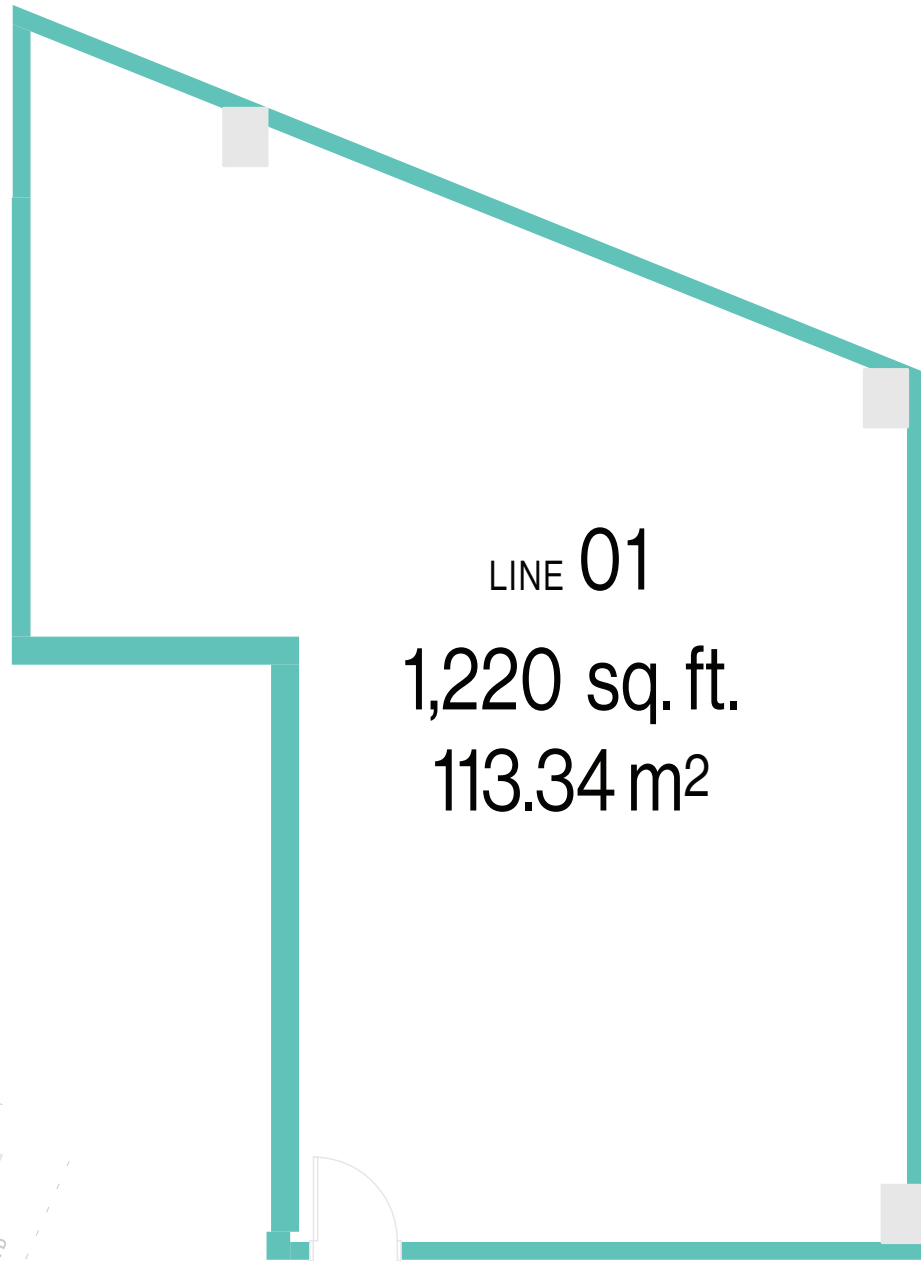



FLOORPLAN

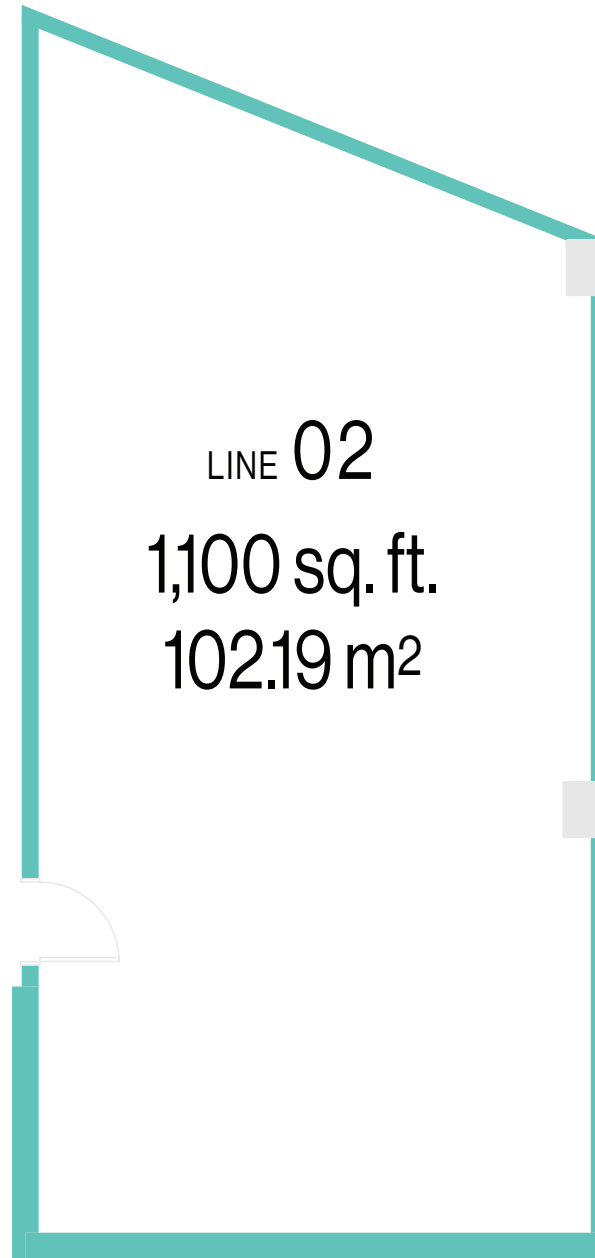

Ⓒ ALL INFORMATION IN THIS BROCHURE, AS WELL AS ANY ATTACHMENTS AND/OR REFERENCES HEREIN, SHALL NOT CONSTITUTE AN OFFER TO SELL OR A SOLICITATION OF AN OFFER TO BUY ANY INTEREST IN ANY SECURITY OR ANY SECURITY DERIVATIVE PRODUCTS OF ANY KIND, OR ANY TYPE OF TRADING OR INVESTMENT ADVICE, RECOMMENDATION OR STRATEGY. NO OFFER TO SELL OR SOLICITATION OF AN OFFER TO BUY AN INTEREST IN ANY SECURITY OR OTHER SUCH PRODUCT MAY BE MADE TO A PROSPECTIVE SUBSCRIBER (I) UNTIL A COPY OF THE APPLICABLE SUBSCRIPTION MATERIALS HAVE BEEN PROVIDED TO AND REVIEWED BY SUCH PROSPECTIVE PURCHASER, WHICH MUST BE COMPLETED AND RETURNED IN ACCORDANCE WITH THE TERMS THEREOF, (II) UNLESS MADE EXCLUSIVELY OUTSIDE THE UNITED STATES TO A PROSPECTIVE SUBSCRIBER WHO IS A NON-U.S. CITIZEN OR NON-U.S. PERMANENT RESIDENT IN ACCORDANCE WITH REGULATION S OF THE SECURITIES ACT OF 1933, AS AMENDED; AND (III) IN ANY JURISDICTION IN WHICH SUCH OFFER OR SOLICITATION IS UNLAWFUL. ANY REPRESENTATIONS TO THE CONTRARY ARE UNLAWFUL. WE MAKE NO GUARANTEE OR REPRESENTATION WITH RESPECT TO THE PERFORMANCE OF ANY INVESTMENT, THE SPECIFIC RATE OF RETURN ON ANY INVESTMENT NOR THE RETURN OF CAPITAL.

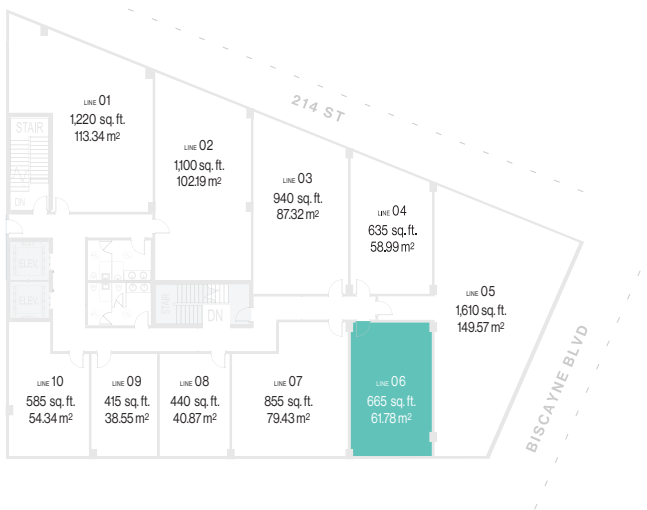
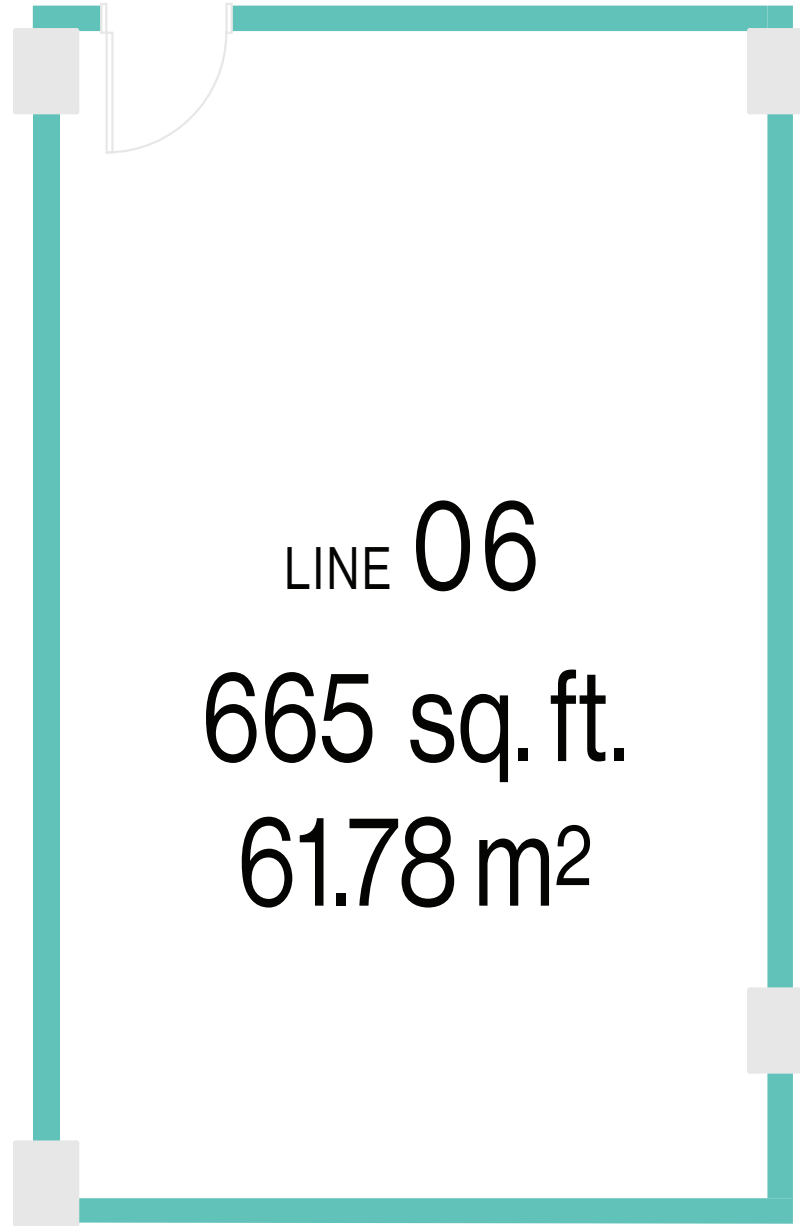



FLOORPLAN



© ALL INFORMATION IN THIS BROCHURE, AS WELL AS ANY ATTACHMENTS AND/OR REFERENCES HEREIN, SHALL NOT CONSTITUTE AN OFFER TO SELL OR A SOLICITATION OF AN OFFER TO BUY ANY INTEREST IN ANY SECURITY OR ANY SECURITY DERIVATIVE PRODUCTS OF ANY KIND, OR ANY TYPE OF TRADING OR INVESTMENT ADVICE, RECOMMENDATION OR STRATEGY. NO OFFER TO SELL OR SOLICITATION OF AN OFFER TO BUY AN INTEREST IN ANY SECURITY OR OTHER SUCH PRODUCT MAY BE MADE TO A PROSPECTIVE SUBSCRIBER (I) UNTIL A COPY OF THE APPLICABLE SUBSCRIPTION MATERIALS HAVE BEEN PROVIDED TO AND REVIEWED BY SUCH PROSPECTIVE PURCHASER, WHICH MUST BE COMPLETED AND RETURNED IN ACCORDANCE WITH THE TERMS THEREOF, (II) UNLESS MADE EXCLUSIVELY OUTSIDE THE UNITED STATES TO A PROSPECTIVE SUBSCRIBER WHO IS A NON-U.S. CITIZEN OR NON-U.S. PERMANENT RESIDENT IN ACCORDANCE WITH REGULATION S OF THE SECURITIES ACT OF 1933, AS AMENDED; AND (III) IN ANY JURISDICTION IN WHICH SUCH OFFER OR SOLICITATION IS UNLAWFUL. ANY REPRESENTATIONS TO THE CONTRARY ARE UNLAWFUL. WE MAKE NO GUARANTEE OR REPRESENTATION WITH RESPECT TO THE PERFORMANCE OF ANY INVESTMENT, THE SPECIFIC RATE OF RETURN ON ANY INVESTMENT NOR THE RETURN OF CAPITAL.

FLOORPLAN

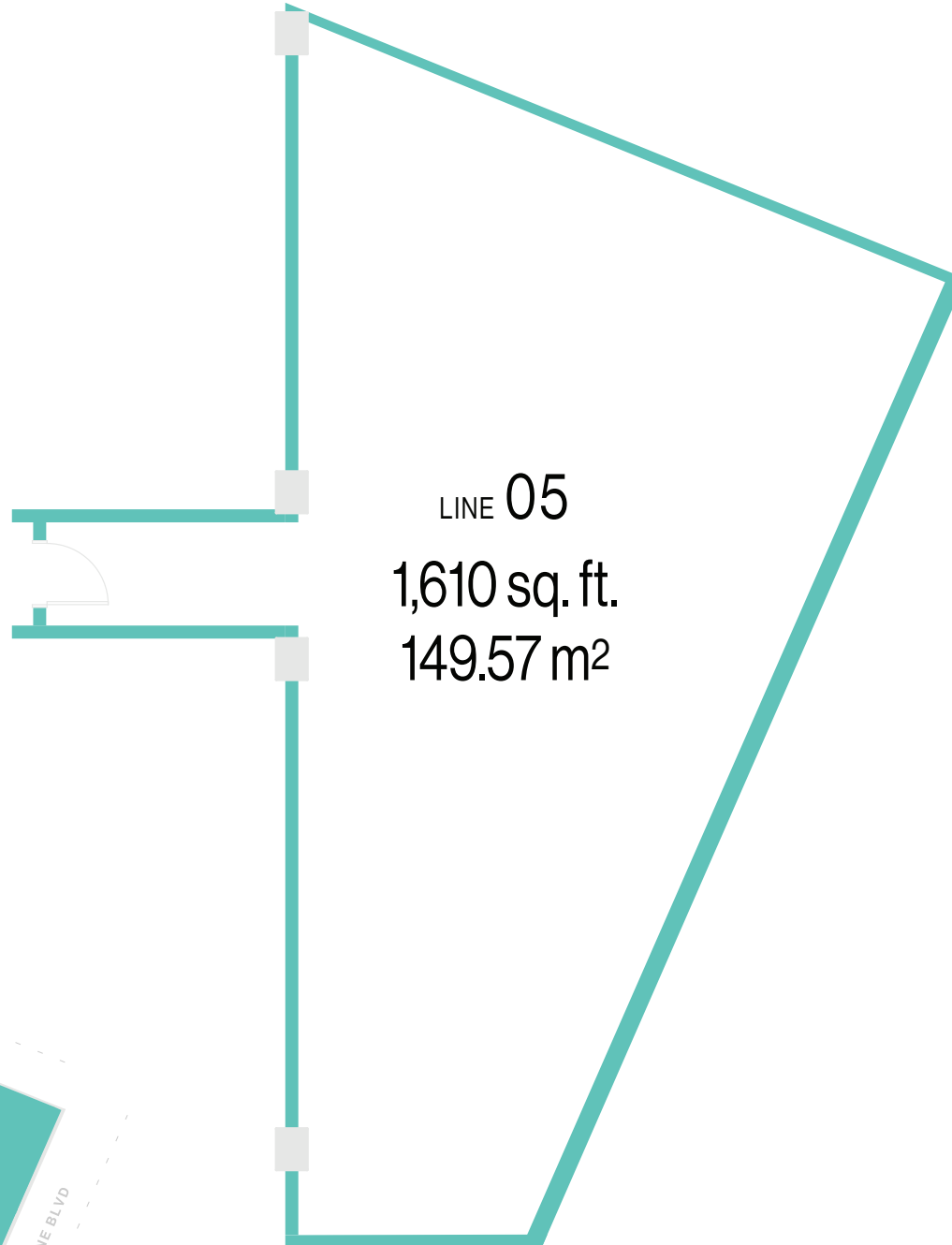



12 | 12
AVENTURA

FLOORPLAN



Ⓔ ALL INFORMATION IN THIS BROCHURE, AS WELL AS ANY ATTACHMENTS AND/OR REFERENCES HEREIN, SHALL NOT CONSTITUTE AN OFFER TO SELL OR A SOLICITATION OF AN OFFER TO BUY ANY INTEREST IN ANY SECURITY OR ANY SECURITY DERIVATIVE PRODUCTS OF ANY KIND, OR ANY TYPE OF TRADING OR INVESTMENT ADVICE, RECOMMENDATION OR STRATEGY. NO OFFER TO SELL OR SOLICITATION OF AN OFFER TO BUY AN INTEREST IN ANY SECURITY OR OTHER SUCH PRODUCT MAY BE MADE TO A PROSPECTIVE SUBSCRIBER (I) UNTIL A COPY OF THE APPLICABLE SUBSCRIPTION MATERIALS HAVE BEEN PROVIDED TO AND REVIEWED BY SUCH PROSPECTIVE PURCHASER, WHICH MUST BE COMPLETED AND RETURNED IN ACCORDANCE WITH THE TERMS THEREOF, (II) UNLESS MADE EXCLUSIVELY OUTSIDE THE UNITED STATES TO A PROSPECTIVE SUBSCRIBER WHO IS A NON-U.S. CITIZEN OR NON-U.S. PERMANENT RESIDENT IN ACCORDANCE WITH REGULATIONS OF THE SECURITIES ACT OF 1933, AS AMENDED; AND (III) IN ANY JURISDICTION IN WHICH SUCH OFFER OR SOLICITATION IS UNLAWFUL. ANY REPRESENTATIONS TO THE CONTRARY ARE UNLAWFUL. WE MAKE NO GUARANTEE OR REPRESENTATION WITH RESPECT TO THE PERFORMANCE OF ANY INVESTMENT, THE SPECIFIC RATE OF RETURN ON ANY INVESTMENT NOR THE RETURN OF CAPITAL.



12 | 12
AVENTURA

FLOORPLAN

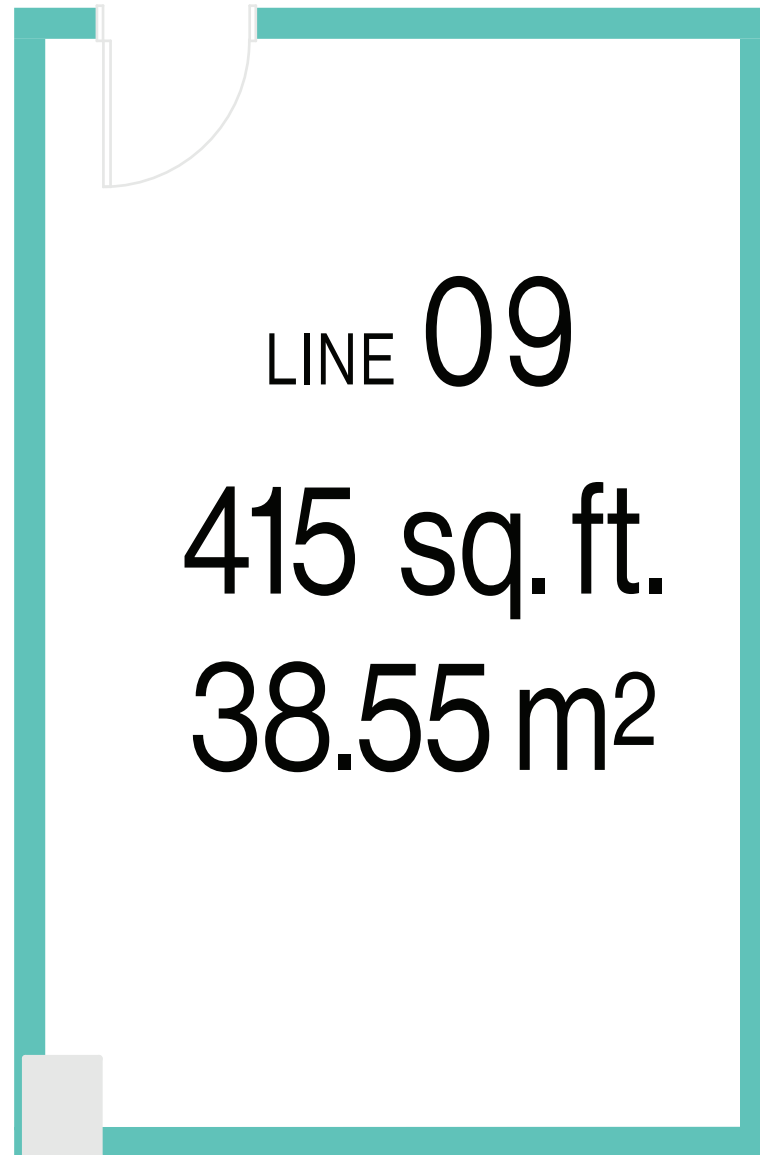

© ALL INFORMATION IN THIS BROCHURE, AS WELL AS ANY ATTACHMENTS AND/OR REFERENCES HEREIN, SHALL NOT CONSTITUTE AN OFFER TO SELL OR A SOLICITATION OF AN OFFER TO BUY ANY INTEREST IN ANY SECURITY OR ANY SECURITY DERIVATIVE PRODUCTS OF ANY KIND, OR ANY TYPE OF TRADING OR INVESTMENT ADVICE, RECOMMENDATION OR STRATEGY. NO OFFER TO SELL OR SOLICITATION OF AN OFFER TO BUY AN INTEREST IN ANY SECURITY OR OTHER SUCH PRODUCT MAY BE MADE TO A PROSPECTIVE SUBSCRIBER (I) UNTIL A COPY OF THE APPLICABLE SUBSCRIPTION MATERIALS HAVE BEEN PROVIDED TO AND REVIEWED BY SUCH PROSPECTIVE PURCHASER, WHICH MUST BE COMPLETED AND RETURNED IN ACCORDANCE WITH THE TERMS THEREOF, (II) UNLESS MADE EXCLUSIVELY OUTSIDE THE UNITED STATES TO A PROSPECTIVE SUBSCRIBER WHO IS A NON-U.S. CITIZEN OR NON-U.S. PERMANENT RESIDENT IN ACCORDANCE WITH REGULATIONS OF THE SECURITIES ACT OF 1933, AS AMENDED; AND (III) IN ANY JURISDICTION IN WHICH SUCH OFFER OR SOLICITATION IS UNLAWFUL. ANY REPRESENTATIONS TO THE CONTRARY ARE UNLAWFUL. WE MAKE NO GUARANTEE OR REPRESENTATION WITH RESPECT TO THE PERFORMANCE OF ANY INVESTMENT, THE SPECIFIC RATE OF RETURN ON ANY INVESTMENT NOR THE RETURN OF CAPITAL.

FLOORPLAN

